

Grease Guardian[®]

Marine Range

*"State-of-the-art technology
built for sea vessels"*



Custom design unit available on request

TRAPS AND REMOVES FATS, OILS & GREASE ON MARINE VESSELS

Stainless steel fabrication in SS316

Traps and removes fats, oil & grease
on Marine Vessels

Intelligent design

Automatically removes 99% of grease and food waste

Self cleaning facility

Product ranges from 1L to 20L per second

Easy to install and maintain, BMS remote monitoring

Full customer support



BS EN ISO 9001:2008



www.fmenvironmental.com



Products layout and combinations

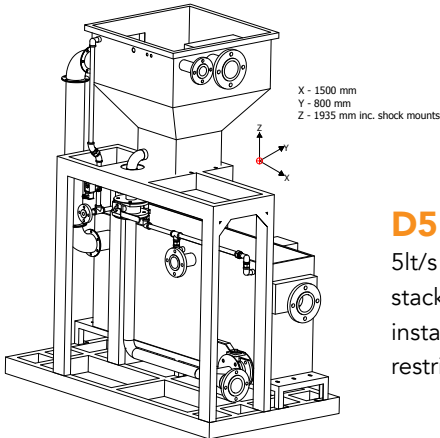

D5
5lt/s In line or stackable for easy installation in restricted space

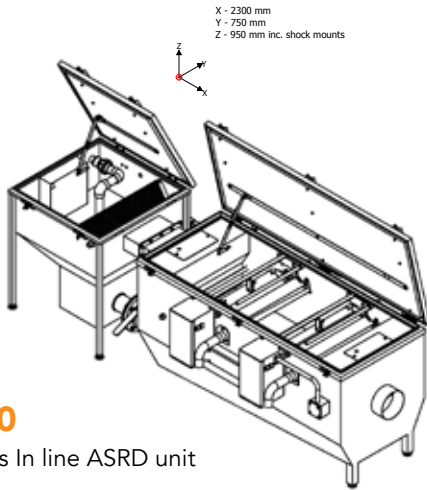

D10
10lt/s In line ASRD unit

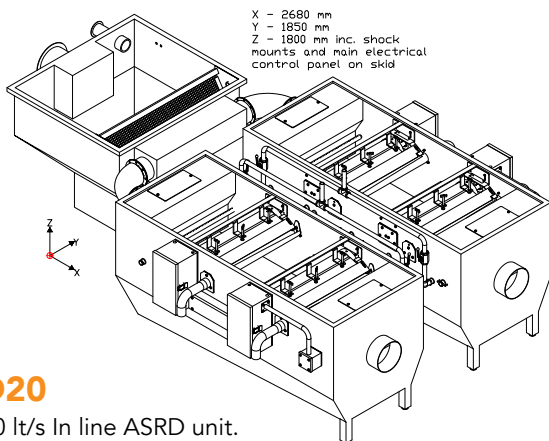

D20
20 lt/s In line ASRD unit.

FOUR-STAGE OPERATION SYSTEM

STAGE 1 Solids Filtration and Transfer (ASRD)

Kitchen waste water enters the unit and any large food particles are trapped by a large screen based in the hopper, where they settle at the bottom. The liquid waste now free of solids continues into the main tank. The settled solids are periodically pumped away by pump into a secondary tank on board for storage (usually available on the ship).

STAGE 2 Grease Trapped

After entering the main tank grease which is lighter than water separates naturally and remains trapped. The heavier clean water leaves the tank under a baffle before being discharged to drain.

STAGE 3 Grease Removal Programme

A pre-programmed removal cycle starts by first agitating the trapped grease waste using diffused air. This helps suspended grease globules to further separate and directs the waste towards the skimming mechanism. The waste is then heated and the grease liquefies. The liquefied grease is then skimmed and transferred to external receptacles to await recycling.

STAGE 4 Self Cleaning

A wash down system is automatically activated to ensure the system remains clean.

OTHER FEATURES

Grease waste can be recycled or sold

Service log and reminder alarms as standard

Compact modularized system that can be disassembled for easy transport on board with possibility of stackable version, skid mounted, with manual or automatic solid removal options

Designed to limit smell, avoid spillages, in 316 SS 16 and 14 gauge according to the model.

MRREV-1



Manufacturers

FM Environmental
Greenbank Industrial Estate
Newry BT34 2QX
Northern Ireland
T: +44(0)28 302 66616
F: +44(0)28 302 63233
E: sales@greaseguardian.com
www.greaseguardian.com

Malta

FM Environmental (Malta) Ltd
Water Technology House
A15B Industrial Estate
Marsa, Malta
T: +356 2122 6172
F: +356 2122 6171
E: fmmalta@fmenvironmental.com
www.fmenvironmental.com

Authorised distributor:

