

GGX75 AST Grease Guardian Installation Details

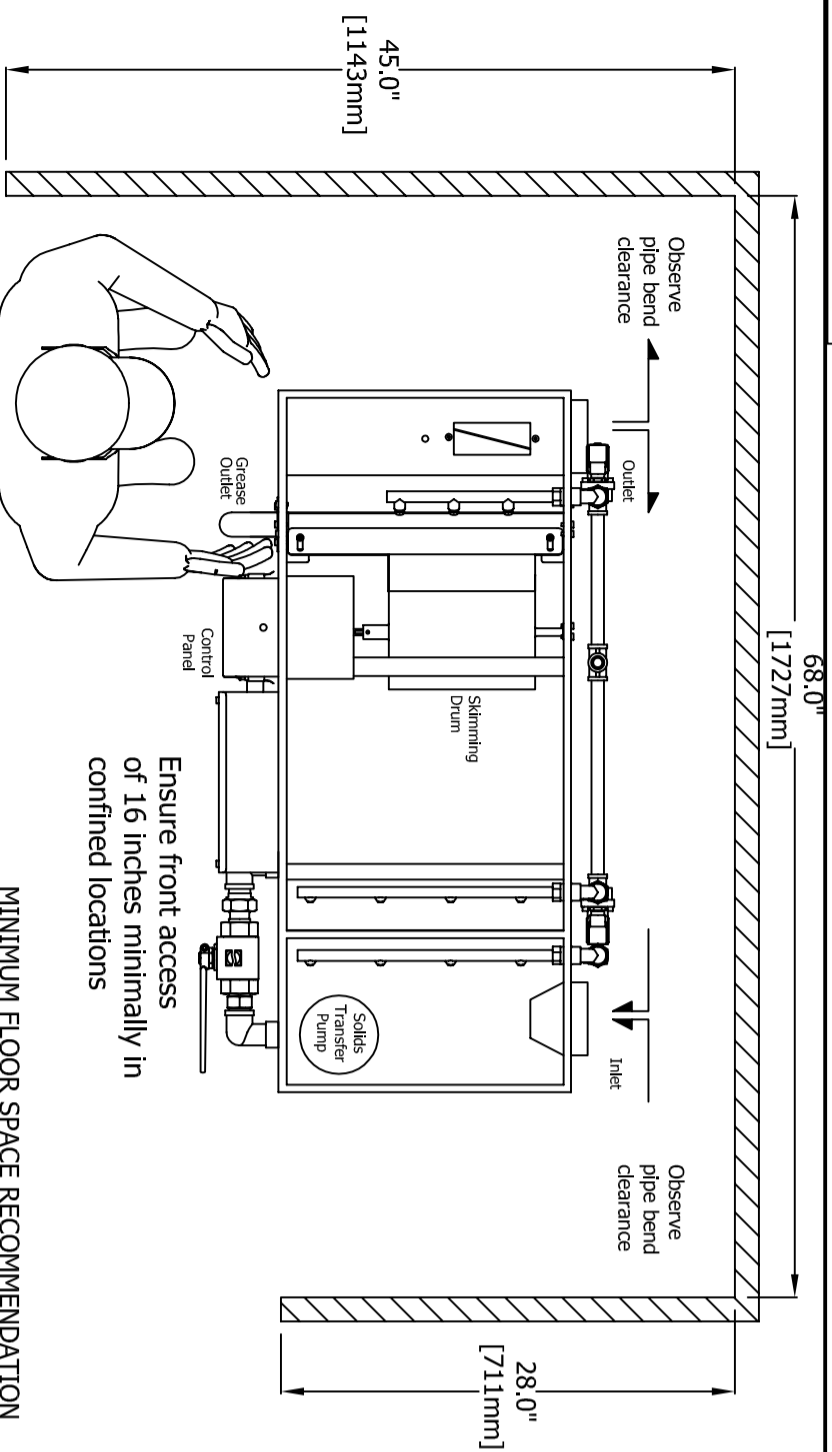

KEY INSTALLATION NOTES:

This unit is to be installed free standing normally at a lower level than the kitchen floor.
 Allow for the minimum dimensions shown.
 Keep outlet piping at a fall of $\frac{1}{8}$ " per foot (1:40).
 Use adjustable rubber pipe connectors as supplied.
 Only switch on after filling system to the required level
 Refer to manual for full installation details.

SPECIFICATION:

Grease Guardian Model GGX75AST:
 Self cleaning automatic grease removal unit, 16 gauge fully welded 304 stainless steel tank, stainless steel internal baffle plate, fully sealed air tight stainless steel lid and robust stainless steel clamps, stainless steel vertical lift solids strainer mesh plate, easy fit pipe couplings supplied, 75 gallons per minute flowrate, and skimming rate of 20 pounds per hour. The GGX75 AST is supplied with an automatic solids transfer (AST) pump with integral automatic screen wash system, rotating grease skimming drum with automatic internal wash system, automatic wash for scum dispersion, integral gas trap, totally enclosed geared drive unit, 600 watt immersion heater with self regulating safety control, programmable controller with interface, energy saving mode and visual alerts. The GGX75 AST is suitable for floor and shelf type mounting. 3 year warranty as standard.

Electrical Details

GGX75AST 110Vac, 1062 Watts, 12.7A*

www.greaseguardianUSA.com

GGX75AST rG

PRE START CHECK UP:

Ensure unit is positioned on a level surface and is plumbed in securely.
 Ensure electrical outlet is fitted with dedicated ground fault circuit breaker.
 Ensure that the unit is filled with water to the correct level.
 Set correct controller date and time as detailed in the manual.
 Ensure that collection receptacle is empty and securely in place.

MINIMUM FLOOR SPACE RECOMMENDATION

GREASE GUARDIAN WORLD:

Grease Guardian World is an interactive online register of all Grease Guardian branded products uploaded and managed by Grease Guardian, distributors and end users.

Grease Guardian World allows users to:

- Upload and manage individual sites
- Monitor specification, service history, supplier details for each Grease Guardian installed
- Upload and view installation photographs
- Upload and view Operation & Maintenance manuals
- Upload and view service engineer reports
- Locate sites using Google Maps linking
- Access and manage accounts on-line
- Manage recycled fats, oils and greases (FOGs)

GGX75 AST Grease Guardian Standard Specification

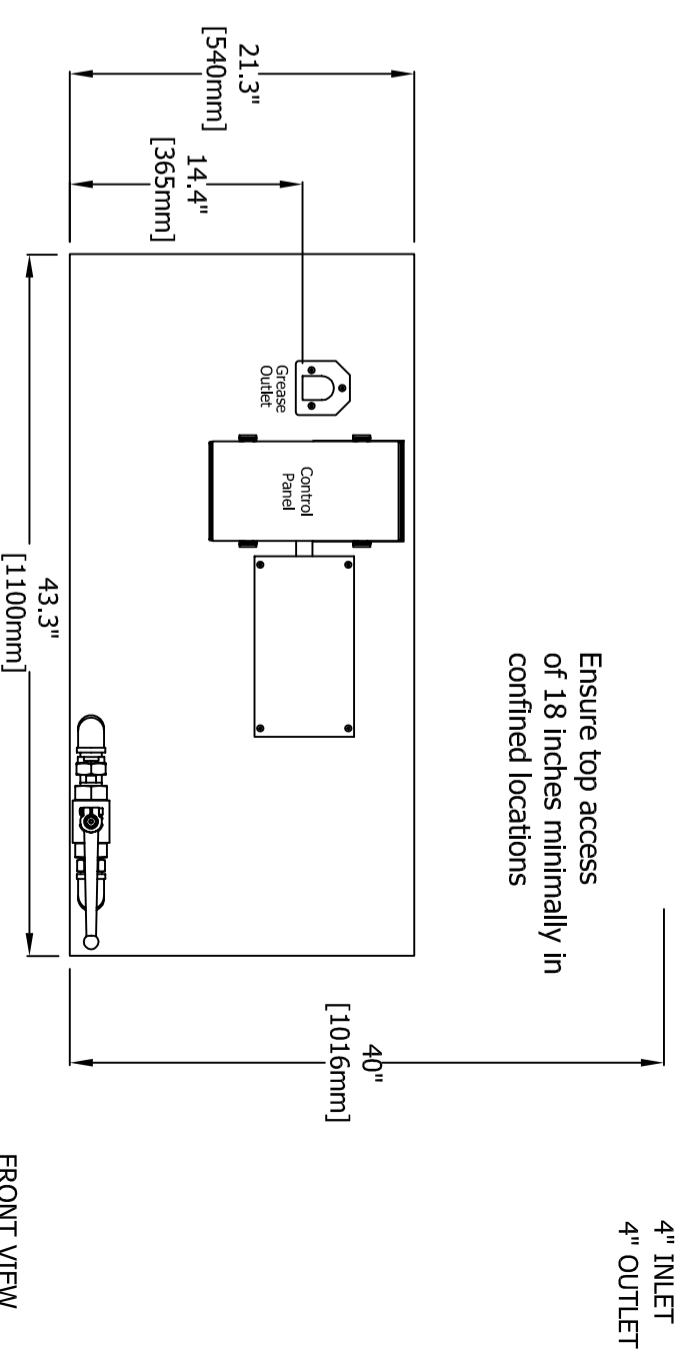

GREASE GUARDIAN X AST STANDARD FEATURES:

- 3 Year Guarantee
- Fully Automatic Grease Removal Unit (AGRU)
- 16 gauge 304 stainless steel welded tank
- Fully sealed air tight lid
- PLC/HMI automatic controller
- Energy saving mode
- Skimming drum with automatic spray bar wash
- Automatic wash-water conditioning system
- Automatic screen mesh spray bar wash
- Automatic Solids Transfer (AST) system
- Grease Guardian World asset management

SIDE ELEVATION

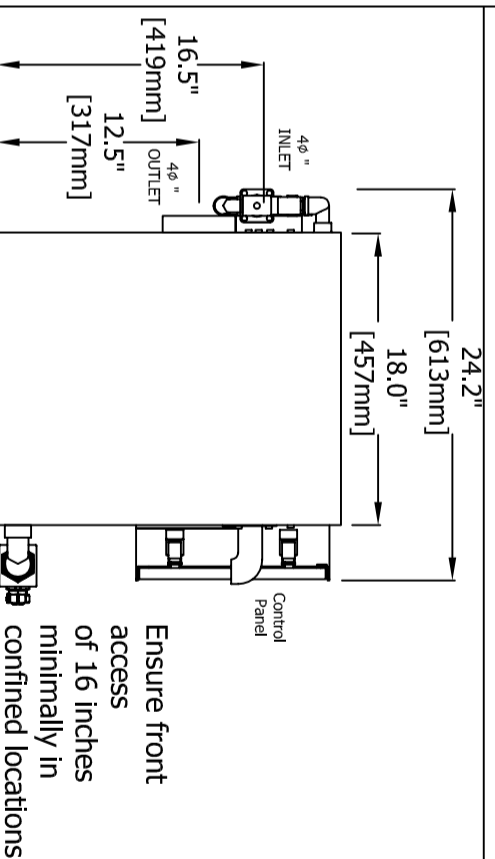

TECHNICAL DATA

Weight _____ 240 pounds
 Exterior Materials _____ 16 gauge AISI304 Stainless Steel
 Interior Materials _____ AISI304 Stainless Steel & Acetal Components
 Maximum Flow Rate _____ 75 GPM
 Solids transfer pump rating (flow/head max) _____ 70gpm/13.5psi (16m3h/9.5m)
 Skimming Rate _____ 20 pounds per hour
 Grease Retention Capacity _____ 150+ pounds
 Wash water system operation requirements (minimum) _____ 12gpm/43.5psi (0.75litres/s@3bar)
 Programming/Control _____ 7day, 24hr multi-function PLC
 Electrical Load _____ 110VAC, 1062W, 12.7A max*

* Current absorbed depends on pump discharge head

Copyright Jan 2015 FM Environmental Ltd. All Rights Reserved. Specification subject to change without notice

GGX75AST rG