

X75 AST Grease Guardian 230VAC Specifications

FRONT VIEW

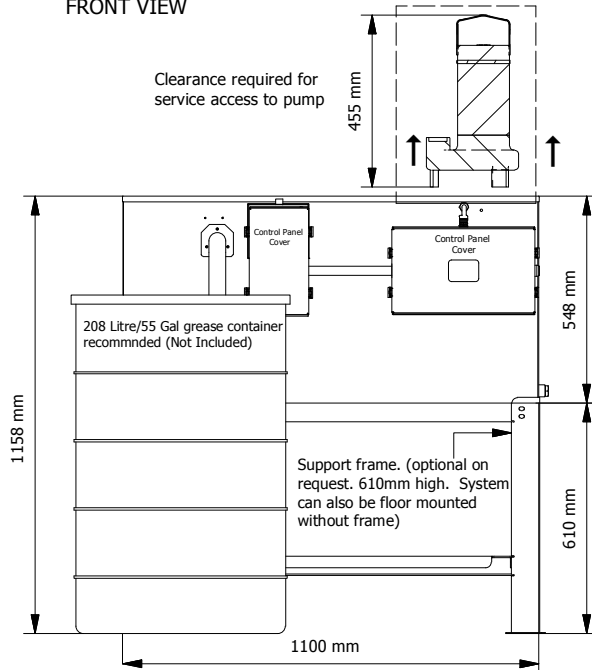

RIGHT END VIEW

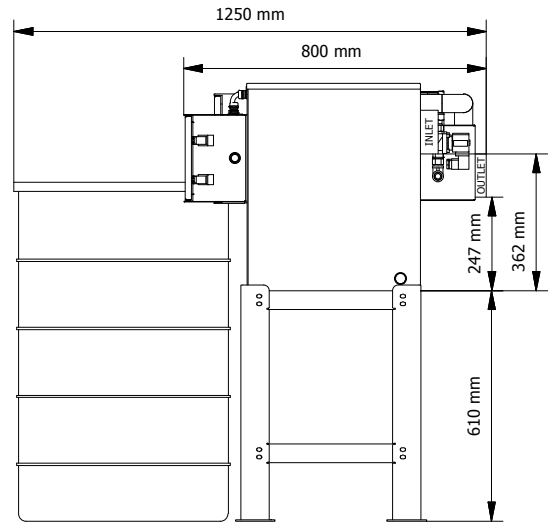

Footprint/Containment area

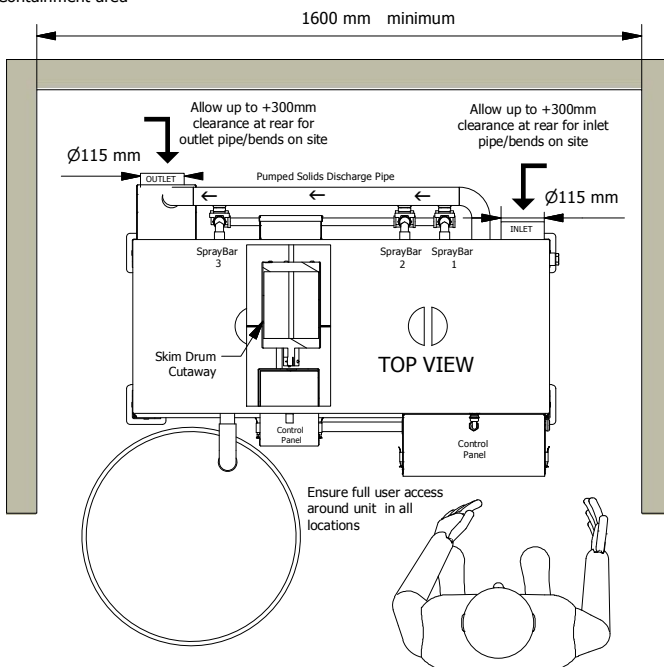

Standard Features

- Automatic Grease Removal Mechanism
- Automatic Solids Transfer pump (AST)
- Automatic Spray Bar Systems x 3
- Water level monitoring sensors x3
- PLC controller with LCD Display Notifications
- Energy Saving Mode
- Bidirectional Inlet and Outlet plumbing ports
- Quick Fit Rubber Couplings
- Grease Heating system
- Pipework and power cabling concealed at rear.
- Building Management Control(zero volt contact for power status)
- 3 year guarantee

Exclusions:

- Grease Collection Vessel, must be sourced locally
- Plumbing pipes /ventilation piping

Options: by FM Environmental on request:

- Support Frame shown (excluded unless requested)
- Upstream coarse solids strainer modules
- Externally mounted blower system (for surface scum dispersal)
- Drum mountable oil level alarm with cycle shut off switch
- Remote system Management via internet - from Jan 2020 only

Key Installation Notes:

Allow for the minimum clearances shown, including clearance for pipe connections and 360 degree user access around unit

Control panels should be fully accessible to service personnel

Electrical supply is single phase. An RCD/ELCB rated 30mA must be installed for all Grease Guardian electrical supplies

Observe all local plumbing regulations for pipe venting, trapping. Observe all local safety and hygiene regulations for room lighting, ventilation and user access.

Note: Not to be treated as an installation guide. Installation guide in full is issued on supply of system.

TECHNICAL DATA

Weight	110 KG(empty)
Material	Exterior, 16 gauge stainless steel, bright finish
Interior	Stainless Steel and Acetal Plastic Components
Maximum Flow Rate	4.75 litres per second
Solids transfer pump rating (flow/head max)	16m ³ h/9.5m
Skimming Rate	up to 12 litres hourly
Grease Retention Capacity	80+ Litres
Hot wash watersupply requirements	minimum 0.75 litres/s @ 3-6 bar (temp 40-60 C)
Programing/Control	24 hour, 7 day, multi functional digital
Electrical Load	230VAC, 2470W, 10.7A max*

*Current absorbed depends on pump discharge head