

GGXM25 Grease Guardian

floor mounted grease interceptor
dimensions in mm. Scale 1:10

System features:

100% Stainless steel construction. Includes front access solids strainer for easy management of food waste. Includes rear side inlet and outlet entry points for convenient connection of pipework. System is rated for 26 kg grease capacity. Biological Dosing Option available on request.

Front View

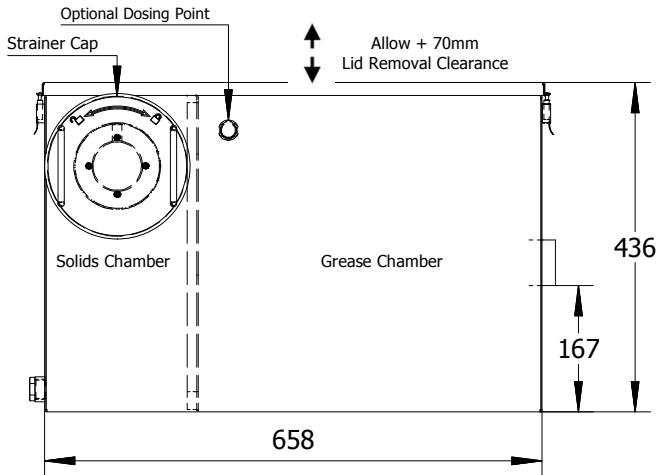

Right Side View

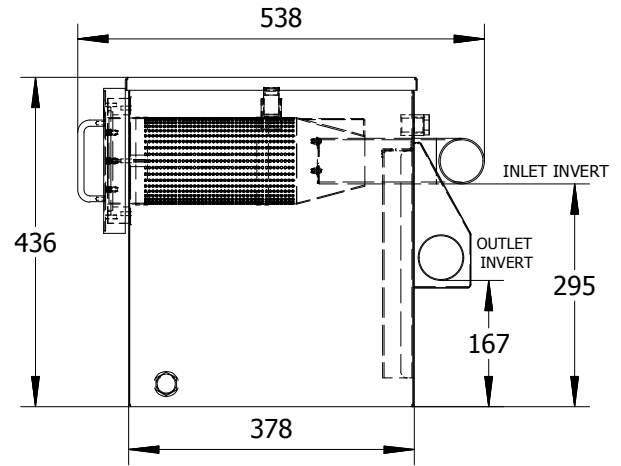

Top View

Minimum Floor-space Recommendation

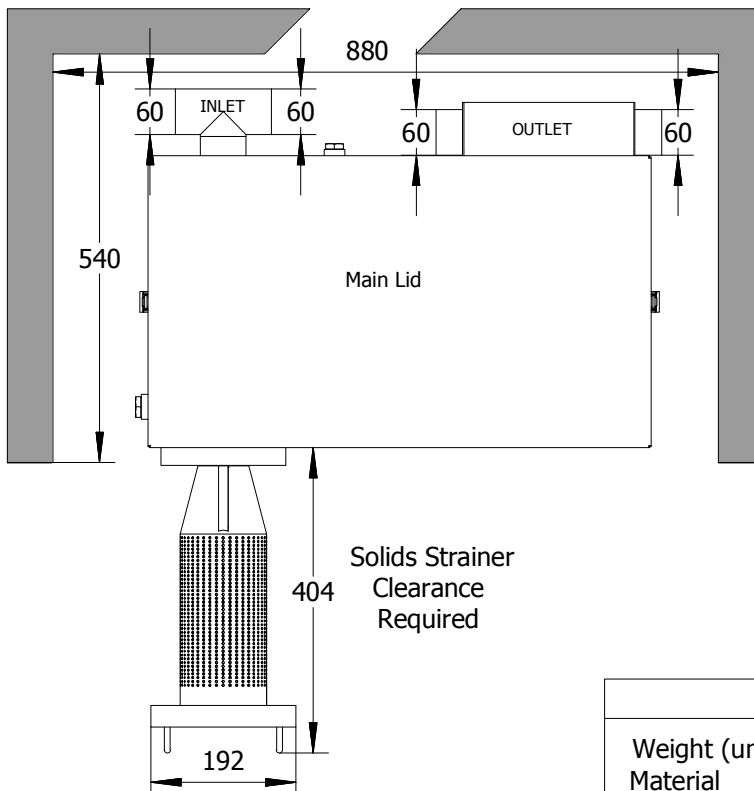

KEY INSTALLATION NOTES:

Provide for the minimum clearances shown.

Inlet and Outlet ports are rear entry with bi directional connection options.

Use rubber adjustable pipe connectors as supplied to connect piping to inlet and outlet.

Keep fall on outlet piping at 1:100 gradient or more. Outlet pipework diameter must be 2 inch minimally for this system.

Ensure pipework to and from this system is ventilated correctly to avoid odours when in use.

Allow adequate access to slide-in strainer.

Allow clearance to remove main lid for servicing and pump out access.

Unit maintenance:
a/ daily disposal of the solids strainer contents.
b/ pump out /vacuum out of grease chamber as detailed in table below.

TECHNICAL TABLE

Weight (unboxed)	25.8kg
Material	16 gauge stainless steel, bright finish
Grease Retention Capacity	26 kg
Total tank capacity	60 litres
Maximum flow rate	1.58 litre per second
Solid Strainer Capacity	3 kg
Tank Pump Out Frequency Passive Unit	7-15 days
Tank Pump Out Frequency Biological Unit	30-45 days
Fluid Dosage Rate Biological Unit	9 litres per month

Tank ratings reference ASME 112.14.3 and PDI G101